

HB 14

Profilbiegeapparat, Aufnahme im Schraubstock
oder Montage auf Tisch

Profile bending machine, for holding in vise
or for table mounting

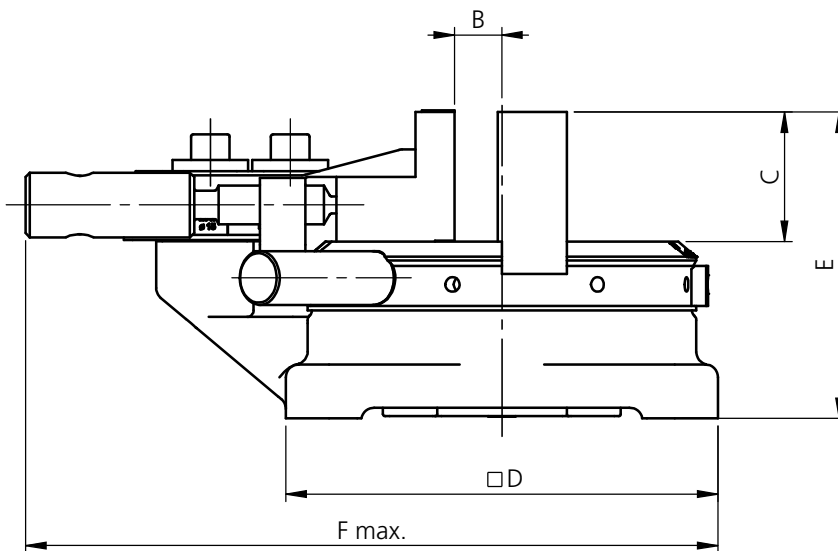
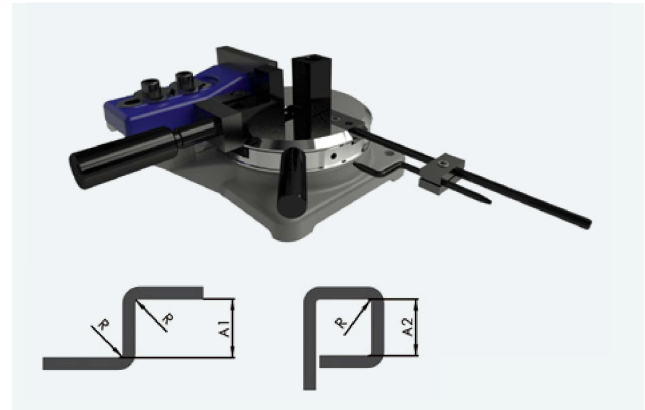

Typ	Type	B	C	D	E	F	Masse (mm)	Dimensions (mm)
HB 14		36	60	200	142	335		

Typ	Beschreibung	Gewicht	Lieferumfang	Bestell-Nr.
Type	Description	Weight	Delivery details	Order No.
HB 14	Profilbiegeapparat, Aufnahme im Schraubstock oder Montage auf Tisch Profile bending machine, for holding in vise or for table mounting	22.4	Biegewerkzeug R=2 mm, 90° Winkel- und Längenanschlag Bedienhebel 2-teilig Bending tool R=2 mm, 90° Material stop and angle stop Bending lever 2-parts	HBM.014.000.01

Max. Biegeleistung Max. bending performance

Dimension	Stahl warmgewalzt	Kupfer
Dimensions	Steel hot rolled	Copper
mm	1.0038 (RSt37-2)	
	60×6	60×7
	40×8	50×8
	25×10	35×10
	20×12	25×12
	13×13	15×15
	ø15	ø16

Lieferbare Biegewerkzeuge Available bending tools

Biegeradius	Biegewinkel	Spannöffnung	Mindestabstände	
Bending radius	Bending angle	Jaw opening	Minimum clearance	
R	°	B	A1	A2
0	90°	36	25	30
2	90°	34	29	34
5	90°	31	35	40
8	180°	28	41	16
10	180°	26	45	20
15	180°	21	55	30
20	180°	16	65	40